



# Marine Valves

For Industrial Marine Applications



ENGINEERING YOUR SUCCESS.



# Contents

Follow Parker Process Control on:



Manually Operated Globe Valve	Page 4-5
Hydraulic Actuated Cryogenic Actuated Globe Valve	Page 6-7
Pneumatically Actuated Cryogenic Actuated Globe Valve	Page 8-9
Cryogenic Swing Check Valve	Page 10-11
Cryogenic Lift Check Valve	Page 12-13
Miniature Needle Globe Valve	Page 14-15
Screw Down Non-return Valve	Page 16-17
Float Level Isolation Valve	Page 18-19
Cryogenic HP Manual Globe Valve	Page 20-21
Cryogenic HP Pneumatic Actuated Globe Valve	Page 22-23
Cryogenic HP Pressure Control Valve	Page 24-25
Cryogenic HP On/Off Pump De-Gassing Valve	Page 26-27
Cryogenic HP Lift Check Valve	Page 28-29

Low Pressure

High Pressure

# Manually Operated Globe Valve

DN15 - 150

The Parker Bestobell range of Stainless Steel, extended globe valves have been designed to eliminate leakages, maximise lifetime operation and reduce maintenance and spares cost for ship operators, whilst providing full compliance with Class requirements

The range is available with either butt weld or flanged options and utilises Parker Bestobell's unique independent bonnet and flange design, eliminating leakage through the flange gasket. Coupled with a three stage packing at the top of the stem, Parker Bestobell globe valves are leak free to atmosphere.

The floating disc arrangement provides absolute sealing across the seat, and is designed to provide a tight, leak free shut off whilst still providing compliance with fire safe requirements for LNGC applications. Nitronic steel bushings provide smooth operation without galling problems.



Stainless Steel extended globe valve

## Features

- Designed and manufactured for use on LNGC, FSRU & FLNG in accordance with BS6364
- Full range of Class 150 Stainless Steel extended globe valves. Class 300 available for sizes up to DN100.
- Independent bonnet and flange design
- Floating disc arrangement
- Firesafe graphite gasket
- Firesafe all metal seat design
- Firesafe graphite, carbon, nitronic steel packing at the top of the stem
- Nitronic steel bushings
- Laser etched nameplates
- DN200 – DN350 options available
- Outside screw option available

## Technical

- Full material traceability backed by BS EN 10204 3.1/3.2 certification
- Temperature range -196°C to + 80°C
- Available in Butt Weld (ANSI b16.25) and Flange (ANSI B16.5) connections
- Shell wall thickness in accordance with ANSI B16.34
- 316 Stainless Steel construction for marine applications
- Fire safe approved to BS EN ISO 10497:2004 & ANSI/API Standard 607 fifth edition June 2005
- Full 3.2 certification to meet Class requirements



DN65 Outside Screw Globe Valve



DN50 Inside Screw Globe Valve



DN50 Flanged Ends

## Materials

	Material
1. Body	ASTM A351 CF3M / CF8M (Flanged)
2. Cover	ASTM A351 CF3M/ BS EN 10088-3 316L 1.4404
4. Disc	ASTM A351 CF8M/BS EN 10088-3 1.4401
5. Stem	BS EN 10088-3 1.4401 (316 St. St.)
6. Gasket	Graphite (316 St. St. Reinforced)
7. Gland Packing	Graphite
8. Fasteners	ASTM A320 B8M / ASTM A194 8M
9. Handwheel	ASTM A351 CF8M

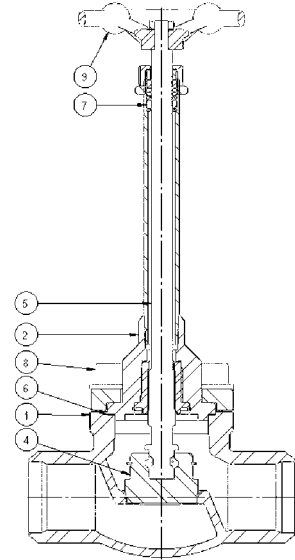

## Specifications

Size	Unit	DN15	DN25	DN40	DN50	DN65	DN80	DN100	DN150
A	mm	114.5	140	165	203	216	241	292	406
B*	mm	300	300	300	300	300	300	400	700
C	mm	177	230	344	395	445	440	618	1023
D	mm	80	80	120	120	165	200	380	600
E	mm	55	66	81	108	146	160	235	280
Butt Weld Schedule	mm	40	40	40	10	10	10	10	10
Weight	kg	1.25	2.4	4.5	8.5	12.5	18	37	151
Cv	US GPM	3.6	13.2	26.5	47	75	108	198	475

\*Other extensions available

### Flanged Ends (Class 150)

Size	Unit	DN15	DN25	DN40	DN50	DN65	DN80	DN100	DN150
F	mm	114.5	140	165	203	216	243	350	406
Flange Diameter	mm	88.9	108	127	152.4	177.8	190.5	228.6	279.4
Flange Thickness	mm	11.5	14.5	17.5	19.05	22.35	24.88	23.88	25.4

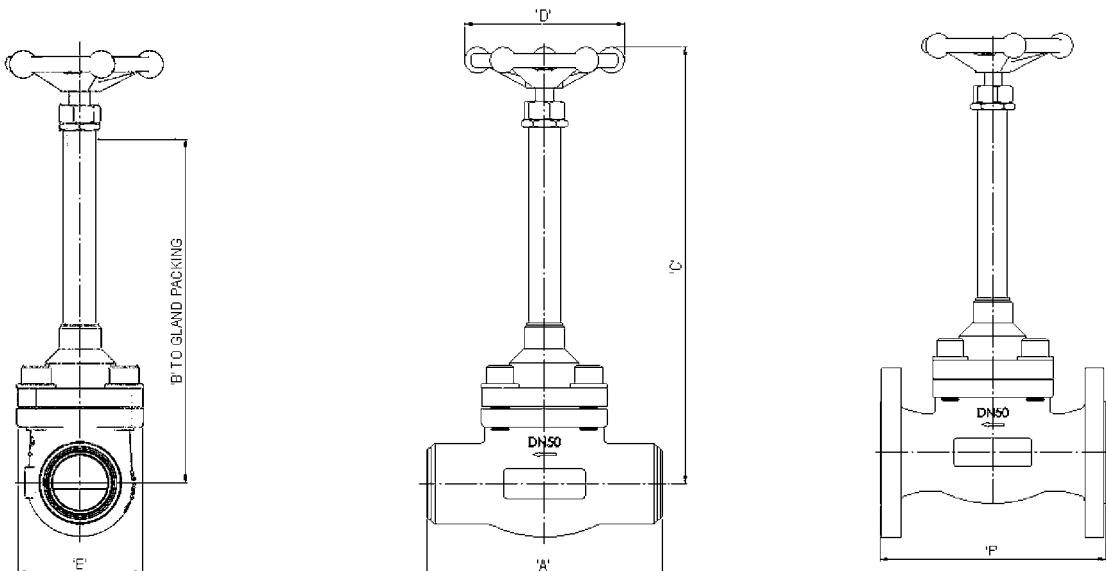

Please contact us for other options.

# Cryogenic Actuated Globe Valve

## Hydraulically Actuated DN25 - DN350

The Parker Bestobell range of Stainless Steel, extended globe valves have been designed to eliminate leakages, maximise lifetime operation and reduce maintenance and spares cost for ship operators, whilst providing full compliance with Class requirements.

The range is available with either butt weld or flanged options and utilises Parker Bestobell's unique independent bonnet and flange design, eliminating leakage through the flange gasket. Coupled with a three stage packing at the top of the stem, Parker Bestobell globe valves are leak free to atmosphere.

The all metal seat of the valves are designed to provide a tight, leak free shut off against the valve disc and allow compliance with fire safe requirements for LNGC applications. Nitronic steel, also Aluminum-Bronze, bushings provide smooth operation without galling problems.

The valves can be operated by either a linear or multi-turn hydraulic actuator, and both types are used for throttling and on/off applications. Position control is provide either by a potentiometer or with a torque switch, and On-Off actuation is controlled by limit switches.



Hydraulically Actuated Stainless Steel Extended Globe Valve

### Features

- Designed and manufactured for use on LNGC, FSRU & FLNG in accordance with BS6364
- Full range of Class 150 Stainless Steel extended globe valves. Class 300 available for sizes up to DN100.
- Independent bonnet and flange design
- Firesafe graphite gasket
- Firesafe all metal seat design
- Firesafe graphite, carbon, nitronic steel packing at the top of the stem
- Nitronic steel bushings
- Linear and hydraulic motor type actuators available
- Throttling and On/Off functions available
- Laser etched nameplates

### Technical

- Full material traceability backed by BS EN 10204 3.1/3.2 certification
- Temperature range -196°C to + 80°C
- Available in Butt Weld (ANSI B16.25) and Flange (ANSI B16.5) connections
- Shell wall thickness in accordance with ANSI B16.34
- 316 Stainless Steel construction for marine applications
- Fire safe approved to BS EN ISO 10497:2004 & ANSI/API Standard 607 fifth edition June 2005
- Full 3.2 certification to meet Class requirements



Emerson Actuator



Emerson Actuator Connection



Centork Actuator



Centork Actuator Connection

## Materials

	Material
1. Body	ASTM A351 CF3M/CF8M (Flanged)
2. Cover	ASTM A351 CF3M/BS EN 10088-3 1.4404
3. Loose Bonnet Flange	ASTM A351 CF8M
4. Disc	ASTM A351 CF8M/1.4401
5. Stem	BS EN 10088-3 1.4401 (316 St. St.)
6. Gasket	Graphite (316 St. St. Reinforced)
7. Gland Packing	Graphite
8. Fasteners	ASTM A320 B8M / ASTM A194 8M

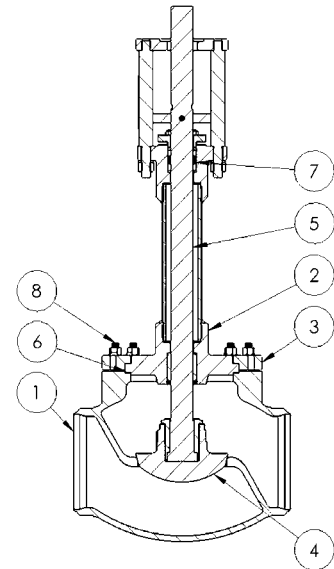

## Specifications

### Butt Weld Ends (Class 150)

Size	Unit	DN25	DN40	DN50	DN65	DN80	DN100	DN200	DN300	DN350
A	mm	140	165	203	216	241	292	495	698	787
B*	mm	300	300	300	300	300	400	650	750	800
C	mm	562	824	874	874	903	1020	1282	1400	1400
D	mm	152	217	217	217	217	217	512	540	540
E	mm	66	81	108	146	160	235	365	495	534
G	mm	80	80	80	98	98	98	175	207	264
H	mm	564	591	604	713	726	848	1435	1600	1718
J	mm	151	151	152	153	153	152	207	208	230
Butt Weld Schedule	mm	40	40	10	10	10	10	10	10	10
Weight	kg	12	40	43	54	60	120	253	395	550
Cv	US GPM	13.2	26.5	47	75	108	198	875	2002	2733

\*Other extensions available

### Flanged Ends (Class 150)

Size	Unit	DN25	DN40	DN50	DN65	DN80	DN100	DN200	DN300
F	mm	140	165	203	216	243	350	495	698
Flange Diameter	mm	108	127	152.4	177.8	190.5	228.6	342.9	482.6
Flange Thickness	mm	14.5	17.5	19.05	22.35	24.88	23.88	28.4	31.9

Class 300 valves available on request

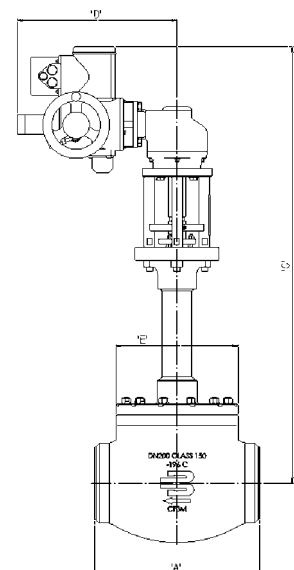
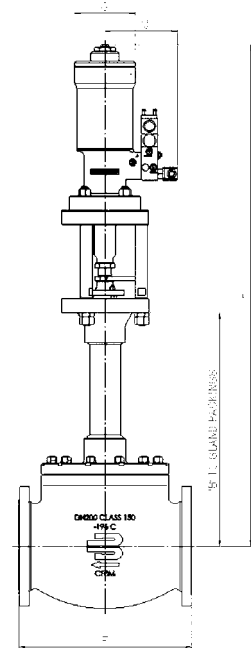

Please contact us for other options.

# Cryogenic Actuated Globe Valve

Pneumatically Actuated  
DN15 - DN150

**The Parker Bestobell range of Stainless Steel, extended globe valves have been designed to eliminate leakages, maximise lifetime operation and reduce maintenance and spares cost for ship operators, whilst providing full compliance with Class requirements.**

The range is available with either butt weld or flanged options and utilises Parker Bestobell's unique independent bonnet and flange design, eliminating leakage through the flange gasket. Coupled with a three stage packing at the top of the stem, Parker Bestobell globe valves are leak free to atmosphere.

The all metal seat of the valves are designed to provide a tight, leak free shut off against the valve disc and allow compliance with fire safe requirements for LNGC applications. Nitronic steel bushings provide smooth operation without.

The valves can be operated for throttling and on/off applications. Position control is provide either by a potentiometer, and On-Off actuation is controlled by limit switches.



Pneumatically Actuated Stainless Steel Extended Globe Valve

## Features

- Designed and manufactured for use on LNGC, FSRU & FLNG in accordance with BS6364
- Full range of Class 150 Stainless Steel extended globe valves. Class 300 available for sizes up to DN100.
- Independent bonnet and flange design
- Firesafe graphite gasket
- Firesafe all metal seat design
- Firesafe graphite, carbon, nitronic steel packing at the top of the stem
- Nitronic steel bushings
- Throttling and On/Off functions available
- Marine paint option for on deck valves
- Laser etched nameplates

## Technical

- Full material traceability backed by BS EN 10204 3.1/3.2 certification
- Temperature range -196°C to + 80°C
- Available in Butt Weld (ANSI b16.25) and Flange (ANSI B16.5) connections
- Shell wall thickness in accordance with ANSI B16.34
- 316 Stainless Steel construction for marine applications
- Fire safe approved to BS EN ISO 10497:2004 & ANSI/API Standard 607 fifth edition June 2005
- Full 3.2 certification to meet Class requirements



Limit Switch



Solenoid

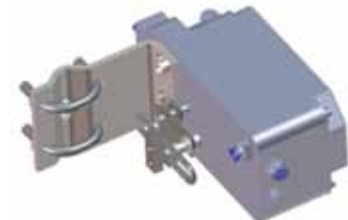

Positioner



## Materials

	Material
1. Body	ASTM A351 CF3M/CF8M (Flanged)
2. Cover	ASTM A351 CF3M/BS EN 10088-3 1.4404
3. Loose Bonnet Flange	ASTM A351 CF8M
4. Disc	ASTM A351 CF8M/1.4401
5. Stem	BS EN 10088-3 1.4401 (316 St. St.)
6. Gasket	Graphite (316 St. St. Reinforced)
7. Gland Packing	Graphite
8. Fasteners	ASTM A320 B8M / ASTM A194 8M

## Specifications

### Butt Weld Ends (Class 150)

Size	Unit	DN15	DN25	DN40	DN50	DN65	DN80	DN100	DN150
A	mm	114.5	140	165	203	216	241	292	406
B*	mm	300	300	300	300	300	300	400	600
C	mm	480	620	637	647	662	682	862	1120
D	mm	162	210	310	310	310	310	415	512
Butt Weld Schedule	mm	40	40	40	10	10	10	10	10
Weight	kg	12	12	40	43	54	60	120	195
Cv	US GPM	13.2	13.2	26.5	47	75	108	198	475

\*Other extensions available

### Flanged Ends (Class 150)

Size	Unit	DN15	DN25	DN40	DN50	DN65	DN80	DN100
F	mm	114.5	140	165	203	216	243	350
Flange Diameter	mm	88.9	108	127	152.4	177.8	190.5	228.6
Flange Thickness	mm	11.5	14.5	17.5	19.05	22.35	24.88	23.88

Class 300 valves available on request

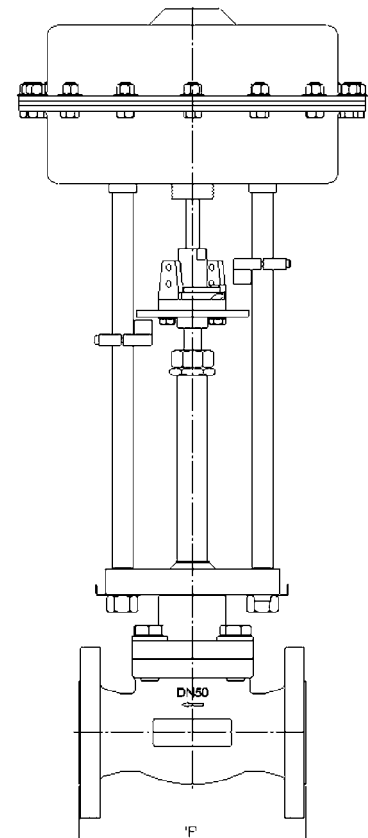
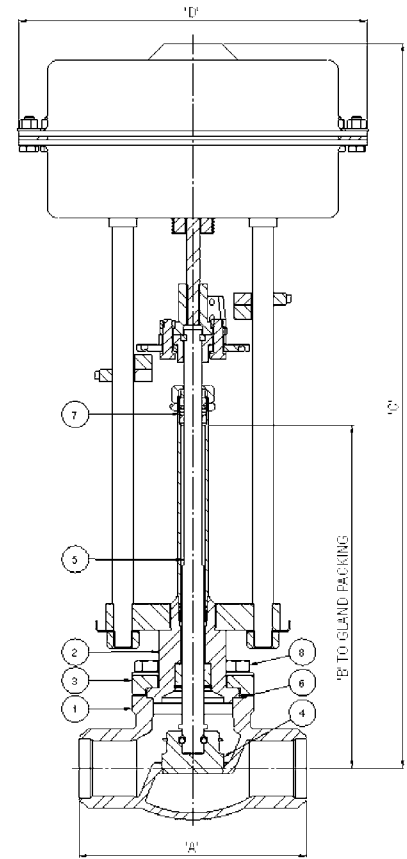

Please contact us for other options.

# Cryogenic Swing Check Valve

DN25 - DN350

**Stainless Steel Swing Check Valve with bolted bonnet. Available with flanged end connections, with easy access to the serviceable parts of the valve**

The valves are designed and manufactured for use with LNG, LPG and other flammable gas services.

Loose bolted bonnet design allows for thermal expansion and contraction and eliminates leakage at the bonnet gasket.

Shell minimum wall thickness in accordance with B16.34 and optional full material traceability backed by BSEN 10204 3.1/3.2 certification.

Flanged end connections to ANSI B16.5 and Butt Weld end connections to B16.25



Stainless Steel Swing Check Valve

## Features

- 316 Stainless Steel construction for marine applications
- Internal hinge design
- PTFE seal ensures a tight shut off
- Quick removal of headworks allow fast, easy maintenance
- Temperature range -196°C to + 80°C
- Fire safe approved to BS EN ISO 10497:2004
- ISO 9001 accreditation
- General design in accordance with BS6364

## Technical

- Full material traceability backed by BS EN 10204 3.1/3.2 certification
- Temperature range -196°C to + 80°C
- Available in Butt Weld (ANSI B16.25) and Flange (ANSI B16.5) connections
- Shell wall thickness in accordance with ANSI B16.34
- 316 Stainless Steel construction for marine applications
- Fire safe approved to BS EN ISO 10497:2004
- Full 3.2 certification to meet Class requirements



DN25 BW SCH Ends



DN50 BW SCH Ends



DN350 Swing Check

## Materials

	Material
1. Body	ASTM A351 CF3M / ASTM A351 CF8M
2. Cover	ASTM A351 CF3M
3. Seat	ASTM A351 CF8M
4. Disc	ASTM A351 CF8M / BS EN 10088-3 1.4401 (316 St. St.)
5. Hinge	ASTM A351 CF8M
6. Hinge Pin	BS EN 10088-3 1.4401 (316 St. St.)
7. Gasket	Graphite (316 St. St. Reinforced)
8. Seat Seal	Graphite
9. Fasteners	ASTM A320 B8M / ASTM A194 8M

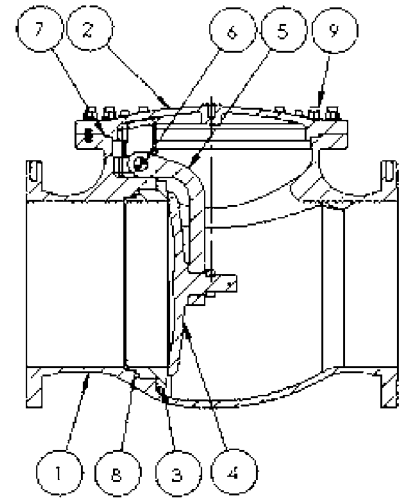

## Specifications

Size	Unit	DN25	DN40	DN50	DN65	DN80	DN100	DN150	DN250	DN350
A	mm	92	121	146	-	260	-	406	-	-
B	mm	76	85	105	129	129	185	217	385	389
C Cover Removal	mm	100	140	175	200	200	280	320	460	460
D	mm	Ø80	Ø110	Ø152	Ø155	Ø155	Ø229	Ø279	Ø483	Ø575
Butt Weld Schedule	mm	10	10	10		10	-	-	-	-
Weight	kg	2	4	10	16	20	36	50	221	343
Cv	US GPM	28	65	122	240	283	518	1240	3565	7130

## Flanged Ends (Class 150)

Size	Unit	DN25	DN40	DN50	DN65	DN80	DN100	DN150	DN250	DN350
F	mm	127	-	203	290	241	356	406	622	787
Flange Diameter	mm	108	-	152	177	191	229	279	406	533
Flange Thickness	mm	11	-	19	22.4	23.8	23.8	25.4	30.3	35

Class 300 valves available on request

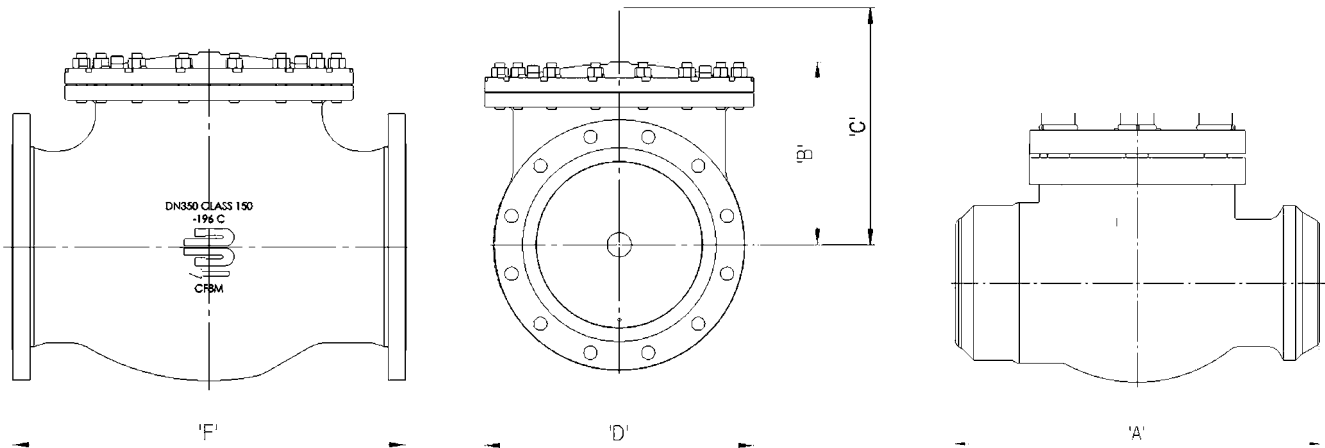

Please contact us for other options.

# Cryogenic Lift Check Valve

DN25 - DN200

**The Parker Bestobell range stainless steel lift check valves have been designed to reduce leakage across the seat, maximise lifetime operation and reduce maintenance and spares cost for ship operators, whilst providing full compliance with Class requirements**

The valve range is available with either butt weld or flanged options designed to ANSI standards, and designed to prevent back flow in LNG systems

Both the valve disc and the metal seat have a final lapped finish to provide the excellent sealing properties across the seat.

The bolted bonnet headworks provides for quick and easy access for maintenance and servicing of the valves.



Stainless Steel Lift Check Valve

## Features

- Designed and manufactured for use on LNGC, FSRU & FLNG and LNG fuel systems in accordance with BS6364
- Full range of Class150 stainless steel swing check valves. Class 300 available for sizes up to DN100
- Firesafe all metal seat design
- Lapped valve disc and seat
- Bolted bonnet headworks
- Firesafe graphite gasket
- Laser etched nameplates

## Technical

- Full material traceability backed by BS EN 10204 3.1/3.2 certification
- Temperature range -196°C to + 80°C
- Available in Butt Weld (ANSI b16.25) and Flange (ANSI B16.5) connections
- Shell wall thickness in accordance with ANSI B16.34
- 316 Stainless Steel construction for marine applications
- Fire safe approved to BS EN ISO 10497:2004 & ANSI/API Standard 607 fifth edition June 2005
- Full 3.2 certification to meet Class requirements



DN25 Lift Check Butt Weld Ends



DN200 Lift Check Flanged Ends

## Materials

	Material
1. Body	ASTM A351 CF3M/CF8M (Flanged)
2. Cover	ASTM A351 CF3M/BSEN 10088-3 1.4404
3. Loose Bonnet Flange	ASTM A351 CF8M
4. Disc	ASTM A351 CF8M/BSEN 10088-3 1.4401 (316 St. St.)
5. Stem	BSEN 10088-3 1.4401 (316 St. St.)
6. Retaining Nut	BSEN 10088-3 1.4401 (316 St. St.)
7. Bush	PTFE
8. Cap	BSEN 10088-3 1.4404 (316L St. St.)
9. Gasket	Graphite (316 St. St. reinforced)
10. Fasteners	ASTM A320 B8M/ASTM A194 8M

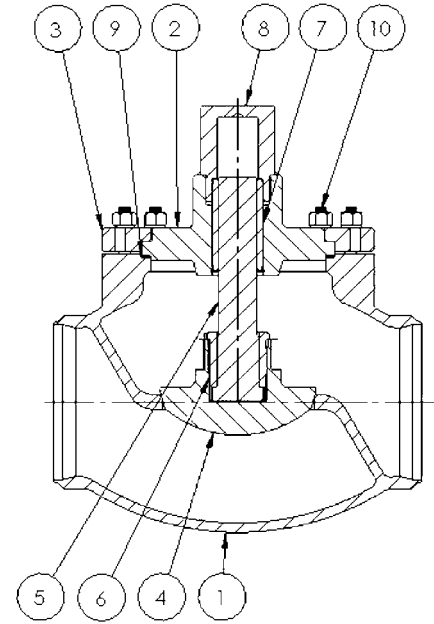

## Specifications

Size	Unit	DN25	DN40	DN50	DN65	DN200
A	mm	140	165	203	216	495
B	mm	60	132	147	166	405
C	mm	Ø80	Ø81	Ø108	Ø146	Ø365
Butt Weld Schedule	mm	10	10	10	10	10
Weight Kg	kg	2	4	4.5	7	135
Cv	US GPM	13.2	26.5	47	75	875

## Flanged Ends (Class 150)

Size	Unit	DN25	DN40	DN50	DN65	DN80
F	mm	140	165	203	216	495
Flange Diameter	mm	108	127	152.4	177.8	342.9
Flange Thickness	mm	14.5	17.5	19.05	22.35	28.4

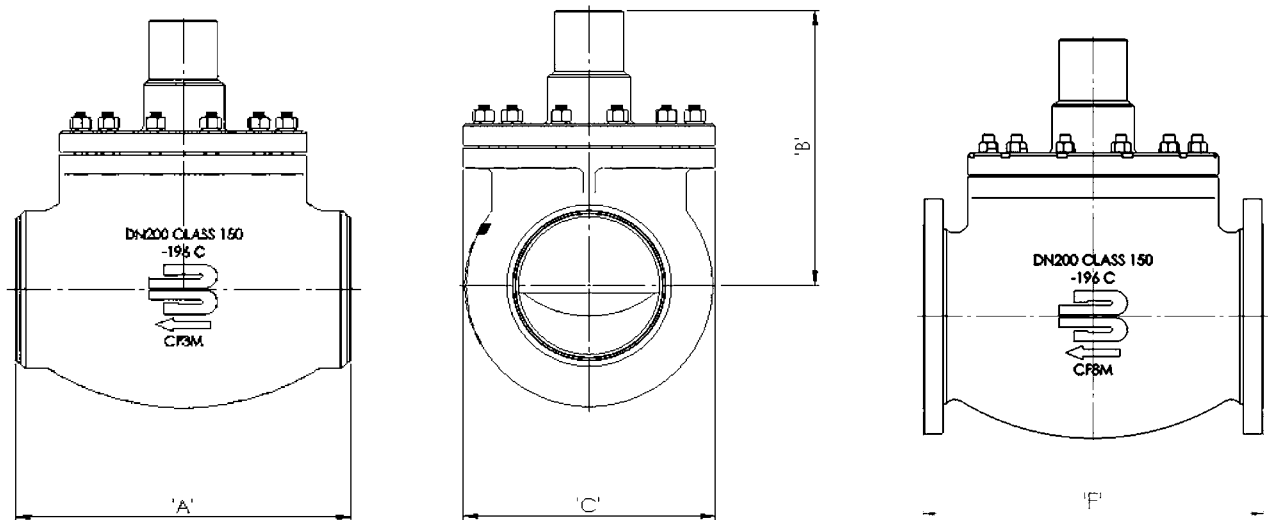

Please contact us for other options.

# Miniature Needle Globe Valve

Bolted Bonnet - Extended and Non-Extended Stem  
DN15 - DN25

**Stainless Steel extended and non-extended spindle needle globe valve with bolted bonnet and integral metal seat.**

Available with socket weld, butt weld and flanged ends, the valve has a conical seat design for a tight shut off. The bolted bonnet allows for simple site maintenance, with easy access to the serviceable parts of the valve.



Stainless Steel Spindle Needle Globe Valve

## Features

- Designed and manufactured for use with LNG, LPG and other flammable gas services
- Temperature range -196°C to + 80°C
- 316 Stainless Steel construction for marine applications
- Fire safe approved to BS EN ISO 10497:2004
- Loose bolted bonnet design allows for thermal expansion and contraction and eliminates leakage at the bonnet gasket
- Anti-blow out stem for operator safety
- Rotating disc prevents galling seat contact and reduces wear
- Quick removal of headworks allows fast, easy maintenance

## Technical

- Designed and engineered for use with Group 1 gases
- ISO 9001 accreditation- design and manufacture to ASTM B31.1 and BSEN 1626
- Optional full material traceability backed by BSEN 10204 3.1/3.2 certification
- **CE** Marking according Pressure Equipment 97/23/EC
- **CE** Marking to Directive 99/36/EC only on written request complete with purchase order



With Buttweld Ends



With Flanged Ends

## Materials

	Material
1. Body	ASTM A351 CF3M /CF8M (Flanged)
2. Cover	BSEN 10088-3 1.4401/1.4404
3. Bonnet Flange	ASTM A351 CF8M SS
4. Disc	BSEN 10088-3 1.4401
5. Stem	BSEN 10088-3 1.4401
6. Gland Packing	Graphite
7. Gasket	Graphite/316 SS
8. Fasteners	ASTM A320 B8M/ASTM A194 8M

## Specifications

Size	Unit	DN15	DN25
A	mm	114.5	140
B	mm	100	150
C	mm	80	80
D	mm	165	215
E	mm	55	66
Butt Weld Schedule	mm	40	40
Weight Kg	kg	1.25	2.4
Cv	US GPM	3.6	13.2

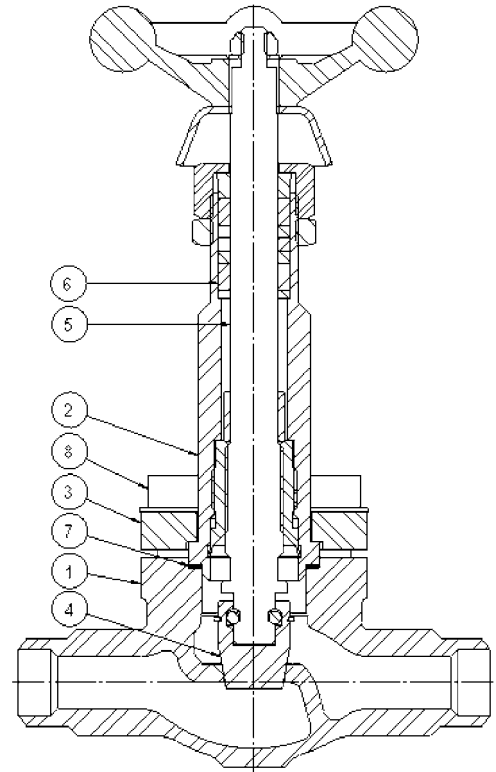

## Flanged Ends (Class 150)

Size	Unit	DN15	DN25
F	mm	114.5	140
Flange Dia	mm	88.9	108
Flange Thickness	mm	11.5	14.5

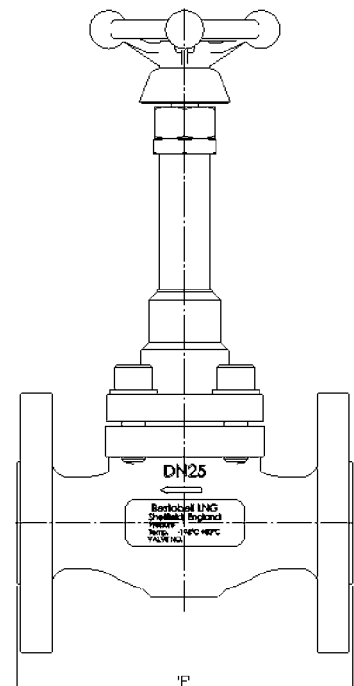
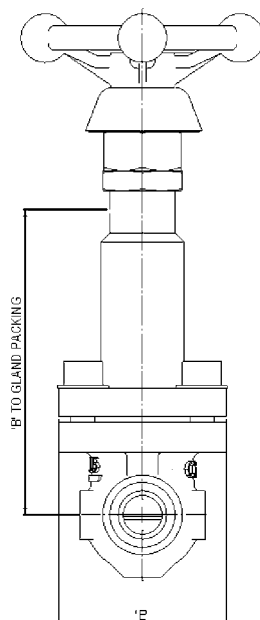
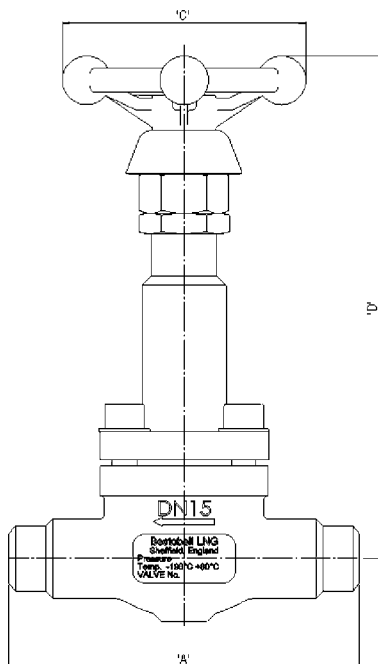

Please contact us for other options.



# Screw Down Non-return Valve

Inside Screw  
DN25 - DN65

**Stainless Steel Extended and non-extended stem globe valve with bolted bonnet and available with socket weld and butt weld ends, the valve is of the cone seat design for drop tight shut off. Unique Parker Bestobell loose flange bolted bonnet design allows for thermal expansion and contraction and eliminates leakage at the bonnet gasket.**

The bolted bonnet allows easy maintenance, even in confined spaces with lower bolting torques required than for an equivalent size union bonnet valve.

All valves are degreased for oxygen duty, assembled in clean room conditions and pressure tested prior to dispatch.

Limit switches available for position indication.

## Features

- Designed and manufactured for use on LNGC, FSRU & FLNG in accordance with BS6364
- Full range of Class 150 Stainless Steel extended globe valves. Class 300 available for sizes up to DN100.
- Independent bonnet and flange design
- Floating disc arrangement
- Firesafe graphite gasket
- Firesafe all metal seat design
- Firesafe graphite, carbon, nitronic steel packing at the top of the stem
- Quick removal of headworks allow fast, easy maintenance
- Nitronic steel bushings
- Laser etched nameplates



Stainless Steel Stem Globe Valve

## Technical

- Class 150 Stainless Steel extended globe valve with bolted bonnet and integral metal seat
- Designed for used with LNG, LPG and other flammable gas service in accordance with BS6364
- Shell wall thickness in accordance with ANSI B16.34
- 316 Stainless Steel construction for marine applications
- Temperature range -196°C to + 80°C
- Fire safe approval to BS EN ISO 10497:2004 & ANSI/API Standard 607 Fifth edition June 2005
- Full 3.2 certification to meet class requirements



DN50 Butt Weld Ends



DN50 Flanged Ends



## Materials

	Material
1. Body	ASTM A351 CF3M/CF8M (Flanged)
2. Cover	ASTM A351 CF3M/BS EN 10088-3 1.4404
3. Loose Bonnet Flange	ASTM A351CF8M
4. Disc	BS EN 10088-3 1.4401 (316 St. St.)
5. Stem	BS EN 10088-3 1.4401 (316 St. St.)
6. Gasket	Graphite (316 St. St. Reinforced)
7. Gland Packing	Graphite
8. Fasteners	ASTM A320 B8M/ASTM A194 8M
9. Handwheel	ASTM A351 CF8M

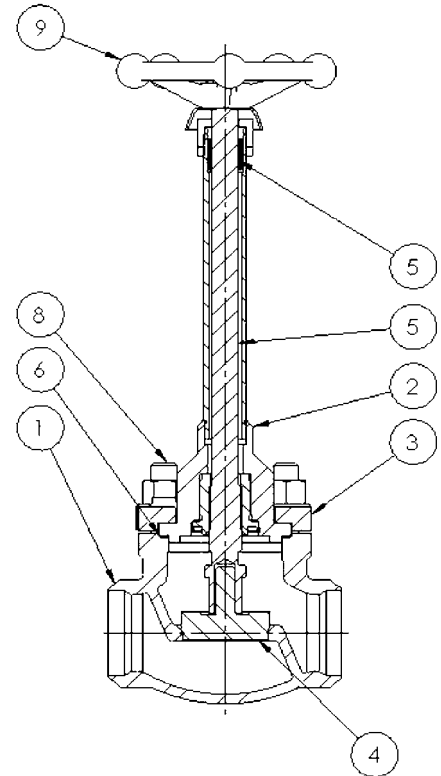

## Specifications

Size	Unit	DN25	DN40	DN50	DN65
A	mm	140	165	203	216
B*	mm	300	300	300	300
C	mm	230	344	395	445
D	mm	80	120	120	165
E	mm	66	81	108	146
Butt Weld Schedule	mm	40	40	10	10
Weight Kg	kg	2.4	4.5	8.5	12.5
Cv	US GPM	13.2	26.5	47	75

### Flanged Ends (Class 150)

Size	Unit	DN25	DN40	DN50	DN65
F	mm	140	165	203	216
Flange Dia	mm	108	127	152.4	177.8
Flange Thickness	mm	14.5	17.5	19.05	22.35

\*Other extensions available

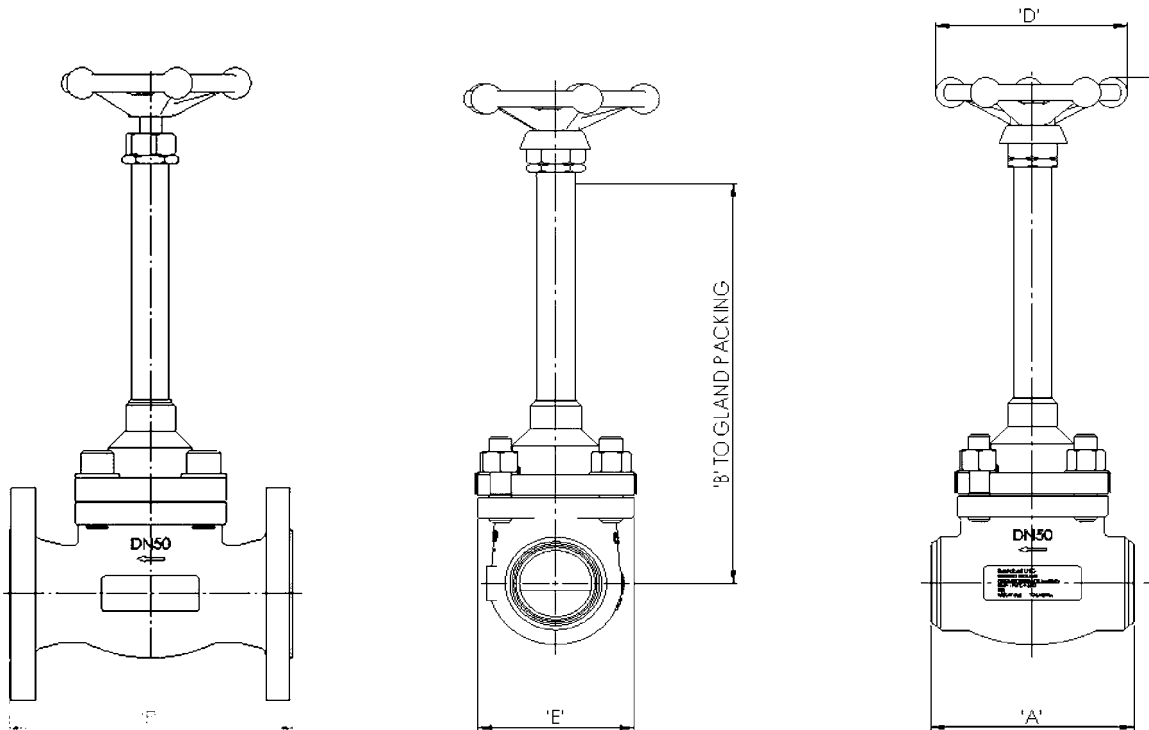

Please contact us for other options.

# Float Level Isolation Valve

DN200 & DN300

FLIV

The Parker Bestobell FLIV valve has been bespoke designed to work in conjunction with Whessoe or Henri secondary float level measurement systems, providing secure isolation of the float from the cargo tank. The FLIV eliminates the problems faced with gate valves of accidental cutting of the float tape that results in both tape and float falling back into the cargo tank.

Should the valve be accidentally closed before the float is fully re-wound, then the closing action of FLIV will result in the tape being trapped on the side of the valve disc rather than being cut, preventing the tape and float from falling back into the cargo tank.

The FLIV is operated by a quarter turn gearbox that has a clear open / shut indicator enabling quick and easy checks on the position of the valve disc. The gearbox is also fitted with 'padlock flanges' so that the valve can be locked to preventing unauthorised operation.

The compact design of the FLIV means that a single operative can operate both the valve and the level gauge with ease.

An integral inspection chamber is incorporated in the valve design for the inspection and / or replacement if the float, thus eliminating the need for a separate fabricated component. The FLIV is fire-safe by design using graphite gaskets on all external joints and PTFE/metal-to-metal backup on the disc.



Float Level Isolation Valve

## Features

- Designed and manufactured for use on LNGC and FSRU
- 316 Stainless Steel construction for marine applications
- Integral inspection chamber
- Easy use handwheel and gearbox
- Padlock to prevent unauthorized operation
- Open/close indication
- Swing disc operation prevents cutting of float tape

## Technical

- Designed and engineered for use with Group 1 gases
- ISO 9001 accreditation- design and manufacture to ASTM B31.1 and BSEN 1626.
- Temperature range -196°C to + 80°C
- Optional full material traceability backed by BSEN 10204 3.1/3.2 certification.

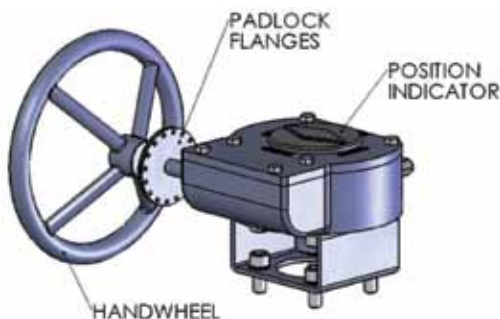

Gearbox Components

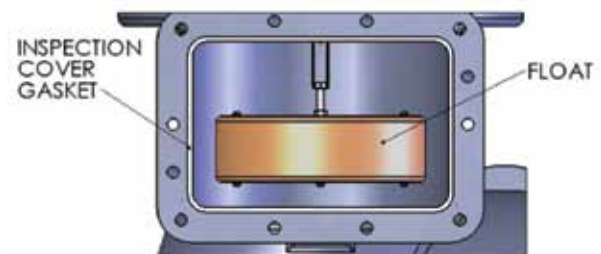

Inspection Chamber

## Materials

	Material
1. Body	ASTM A351 CF8M
2. Bonnet	ASTM A351 CF8M
3. Inspection Cover	ASTM A351 CF8M
4. Hinge	ASTM A351 CF8M
5. Drive Pin	Super Dulux Zeron 100
6. Disc	ASTM A351 CF8M
7. Seat	ASTM A351 CF8M
8. Sealing Ring	PTFE
9. Gasket	Graphite (316 St. St. Reinforced)
10. Gland Packing	Graphite
11. Fasteners	ASTM A320 B8M / ASTM A194 8M

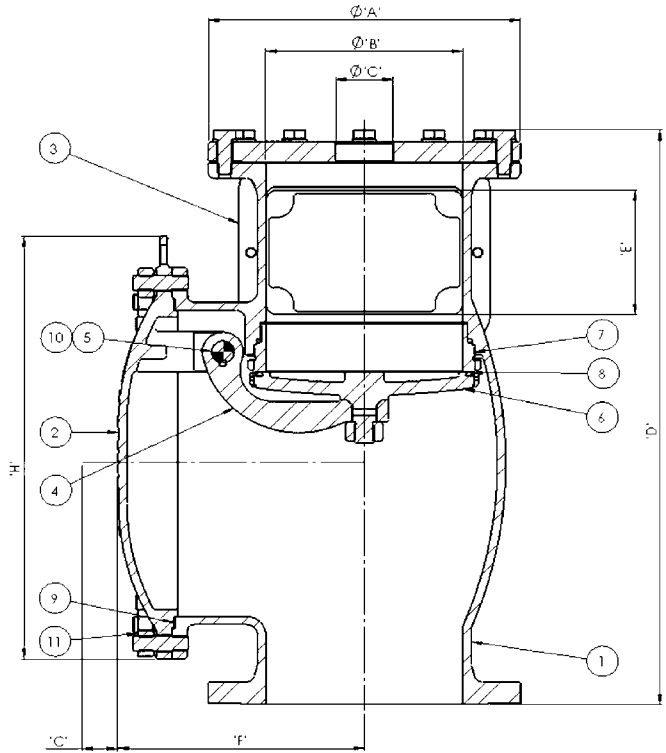

## Specifications

Size	Unit	DN200	DN300
A	mm	140	250
B	mm	121	250
C	mm	146	300
D	mm	178	300
E	mm	178	300
F	mm	292	400
G	mm	406	600
H	mm	495	650
Weight	kg	698	750

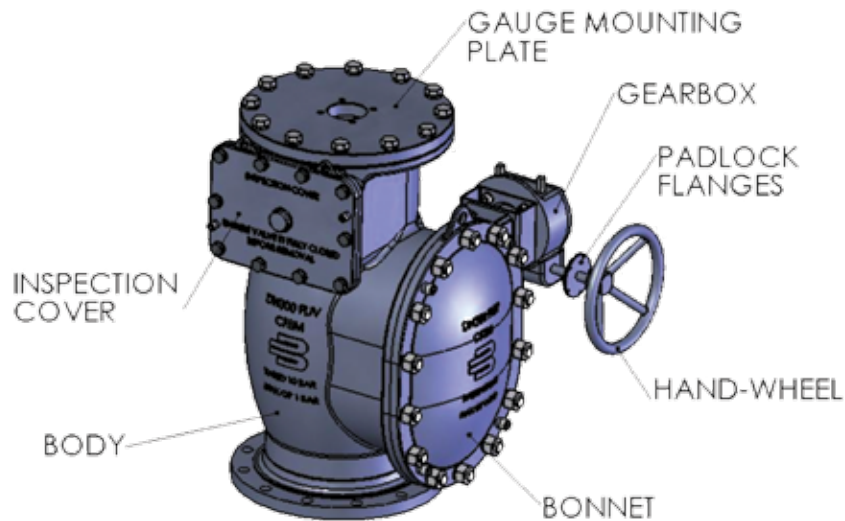

Please contact us for other options.

# Cryogenic HP Manual Globe Valve

Class 2500 (370 Bar)

DN15 - 100 (1/2" - 4")

**The Parker Bestobell range of HP globe valves have been designed specifically for the MAN ME-GI fuel gas systems operating at 320 bar pressure or higher. The range covers all of the necessary manual valve applications within the system.**

The range is offered with six CV profiles from 5 USGPM up to 30 USGPM, and three standard body sizes. These will cover both cryogenic and gas phases in the system. Pressure drop can be minimised by selecting the correct CV profile for the system conditions and flow rates. The end connection can then be machined to suit.

The range is available with various size butt weld connections and utilises Parker Bestobell's unique independent bonnet and flange design that eliminates leakage through the flange gasket. Seat leakage at high pressure is also eliminated through careful lapping of the seat and disc faces.

The valves are available with 400mm extended stem for the cryogenic phase, and short stem for the gas phase or for valves that see low flow conditions in cryogenic service. The smallest body size can be used as an instrumentation valve with NPT connections.



HP Manual Globe Valve

## Maximum Working Pressure (MWP)

Up to 370 bar (5366 psi) at -196°C to +80°C

## Features

- Unique Bestobell loose flange bolted bonnet design allows for thermal expansion and contraction and eliminates leakage at the bonnet gasket
- Lapped metal-to-metal seat ensures tight shut off at all times
- Valve is fire safe by design
- Designed and engineered specifically for cryogenic service
- Anti-blowout spindle and one-piece high strength design for
- Precision machined one-piece extension tube cover with integral bush for high pressure use
- Fast/easy maintenance of disc
- Long life carbon and graphite gland packing
- Gearboxes available in marine grade paint for on deck applications

## Technical

- Designed and engineered for use with LNG.
- Designed and manufactured in accordance with ASTM B31.1, BSEN 1626 and BS ISO 21011.
- Optional full material traceability backed by BSEN 10204 3.1/3.2 certification.
- 316L Stainless Steel construction for marine applications
- Temperature range -196°C to + 80°C

## CV15: Pressure Drop v Flow At -163°C LNG

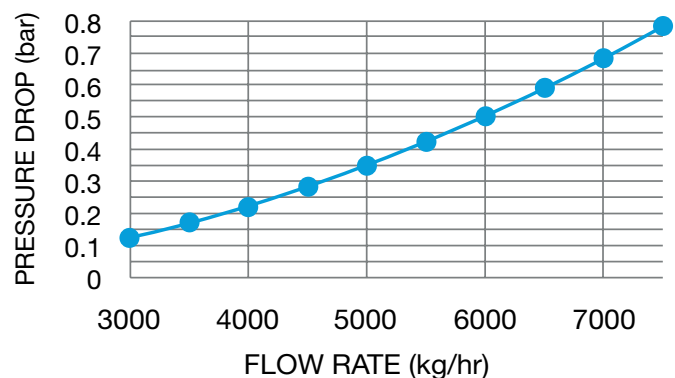

## Materials

1. Body	SS 316L BSEN 10088-3 1.4401/1.4404
2. Cover	SS 316 BSEN 10088-3 1.4401
3. Bonnet Flange	SS 316 BSEN 10088-3 1.4401
4. Disc	SS 316 BSEN 10088-3 1.4401
5. Stem	SS 316 BSEN 10088-3 1.4401
6. Gasket Bonnet	SS 316 / Graphite
7. Gland Packing	Graphite / Carbon
8. Fasteners	SS ASTM A320 B8M (Class 2)
9. Hand Wheel	SS ASTM A351 CF8M

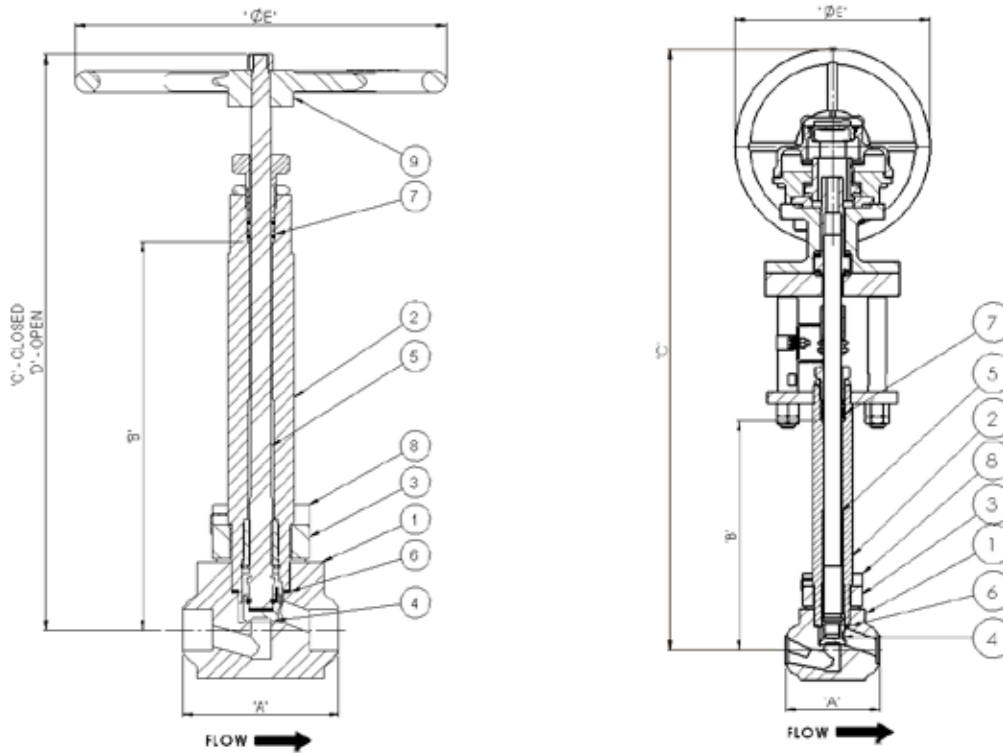

## Specifications

Size	Unit	CV5	CV10	CV15	CV30
A	mm	112	145	160	160
B	mm	100/200	200/400	200/400	200
C : Closed	mm	218/318	390/590	390/590	820
D : Open	mm	228/328	400/600	400/600	-
E	mm	80	380	380	330
End Connections	mm	DN15,20,25	DN32,40,50, 65	DN50,65,80,100	
End Connections	Inches	½", ¾", 1"	1¼", 1½", 2", 2½"	2", 2½", 3", 4"	
Pipe Schedule		40/80/160/XXS	160/XXS	160/XXS	160/XXS
Weight	kg	4	35	35	90
Actuation Type		Hand wheel	Hand wheel	Hand wheel	Gearbox

Please contact us for other options.

# Cryogenic HP Pneumatic Actuated Globe Valve

Class 2500 (370 Bar)  
DN15 - 100 (1/2" - 4")

The Parker Bestobell range of HP globe valves have been designed specifically for the MAN ME-GI fuel gas systems operating at 320 bar pressure or higher. The range covers all of the necessary actuated valve applications within the system and allows end users to select on/off or control valves where necessary.

The range is offered with four CV profiles from 5 USGPM up to 30 USGPM, and two standard body sizes. These will cover both cryogenic and gas phases in the system. Pressure drop can be minimised by selecting the correct CV profile for the system conditions and flow rates. The end connection can then be machined to suit.

The range is available with various size butt weld connections and utilises Parker Bestobell's unique independent bonnet and flange design that eliminates leakage through the flange gasket. Seat leakage at high pressure is also eliminated through careful lapping of the seat and disc faces.

The valves are available with 400mm extended stem for the cryogenic phase, and short stem for the gas phase or for valves that see low flow conditions in cryogenic service.



DN50 Pneumatic Actuated Stainless Steel Globe Valve

## Maximum Working Pressure (MWP)

Up to 370 bar (5366 psi) at -196°C to +80°C

## Features

- Unique Bestobell loose flange bolted bonnet design allows for thermal expansion and contraction and eliminates leakage at the bonnet gasket
- Lapped metal-to-metal seat ensures tight shut off at all times
- Valve is fire safe by design
- Designed and engineered specifically for cryogenic service
- Anti-blowout spindle and one-piece high strength design for operator safety
- Precision machined one-piece extension tube cover with integral bush for high pressure use
- Fast/easy maintenance of disc
- Long life carbon and graphite gland packing
- Actuators available in "fail open" and "fail close" operation
- Actuators available in marine grade paint for on deck applications

## Technical

- Designed and engineered for use with LNG.
- Designed and manufactured in accordance with ASTM B31.1, BSEN 1626 and BS ISO 21011.
- Optional full material traceability backed by BSEN 10204 3.1/3.2 certification.
- 316L Stainless Steel construction for marine applications
- Temperature range -196°C to + 80°C

CV15: Pressure Drop v Flow At -163°C LNG

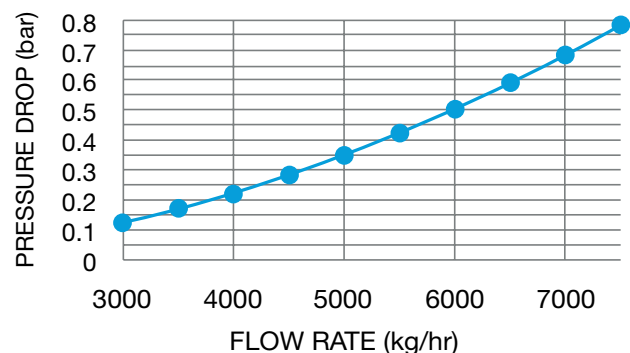

## Materials

1. Body	SS 316L BSEN 10088-3 1.4401/1.4404
2. Cover	SS 316 BSEN 10088-3 1.4401
3. Bonnet Flange	SS 316 BSEN 10088-3 1.4401
4. Disc	SS 316 BSEN 10088-3 1.4401
5. Stem	SS 316 BSEN 10088-3 1.4401
6. Gasket Bonnet	SS 316 / Graphite
7. Gland Packing	Graphite / Carbon
8. Fasteners	SS ASTM A320 B8M (Class 2)
9. Actuator	Various

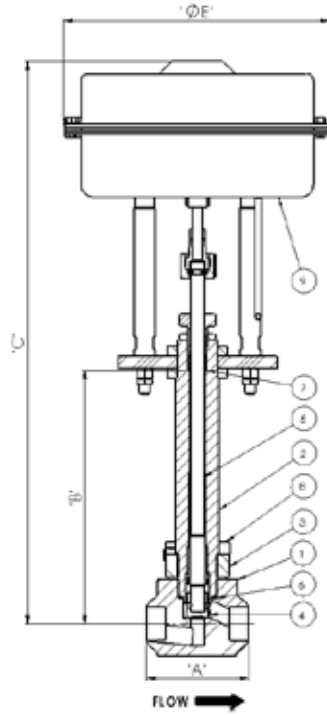

CV 5/10 Single Cylinder

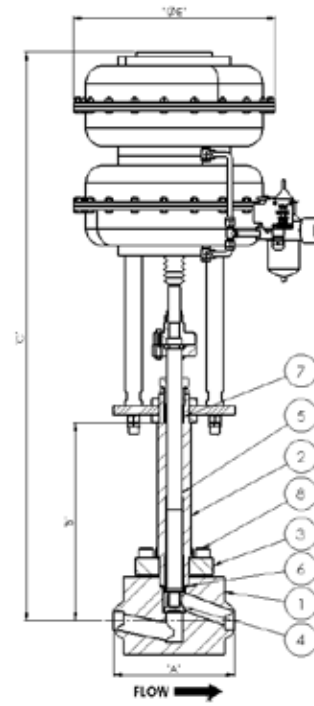

CV 15/20/25/30 Tandem Cylinder

## Specifications

Size	Unit	CV5	CV10	CV15	CV30	
A	mm	145	145	160	160	
B	mm	200/400	200/400	200/400	200	
C	mm	690/890	690/890	970/1170	1170	
E	mm	415	415	415	415	
End Connections	mm	DN15,20,25,32,40,50,65				DN50,65,80,100
End Connections	Inches	1/2", 3/4", 1", 1 1/4", 1 1/2", 2", 2 1/2"				2", 2 1/2", 3", 4"
Pipe Schedule		40/80/160/XXS	160/XXS	160/XXS	160/XXS	
Weight	kg	106	106	152	152	
Actuator Type		Single	Single	Tandem	Tandem	
Actuator Model		MA3.41	MA3.41	TMA.141	TMA.141	
Max Closing Force	kN	35	35	67	67	

Please contact us for other options.



# Cryogenic HP Pressure Control Valve

Class 2500 (370 Bar)

DN15 - 65 (1/2" - 2 1/2")

**The Parker Bestobell range of HP globe valves have been designed specifically for MAN ME-GI fuel gas systems operating at 320 bar pressure or higher. The HP Pressure Control Valve has been specifically designed to fine control pressure in the main line before and after the evaporator.**

The valve is designed to reduce pressure in the main fuel line by safely discharging LNG from 320 Bar to less than 10 Bar. The CV has been significantly reduced to prevent excessive pressure loss in the main fuel line. The valve is supplied with a removable orifice plate so that the CV can be adjusted during commissioning if needed. By adjusting the CV allows for fine tuning of the flow rate and pressure drop through the orifice plate to suit operating conditions

The HP Pressure Control valve is available with various size butt weld connections to suit the pipe size and utilises Parker Bestobell's unique independent bonnet and flange design that eliminates leakage through the flange gasket. Seat leakage at high pressure is also eliminated through careful lapping of the seat and disc faces. The valves are available with 400mm extended stem for use in the cryogenic phase.



HP Pressure Control Valve

## Maximum Working Pressure (MWP)

Up to 370 bar (5366 psi) at -196°C to +80°C

## Features

- Unique Bestobell loose flange bolted bonnet design allows for thermal expansion and contraction and eliminates leakage at the bonnet gasket
- Removable orifice plate to adjust flow and pressure drop
- Discharge cage to reduce sound and cavitation
- Lapped metal-to-metal seat ensures tight shut off at all times
- Valve is fire safe by design
- Designed and engineered specifically for cryogenic service
- Anti-blowout spindle and one-piece high strength design for operator safety
- Precision machined one-piece extension tube cover with integral bush for high pressure use
- Fast/easy maintenance of disc
- Long life carbon and graphite gland packing
- Actuators available in "fail open" and "fail close" operation

## Technical

- Designed and engineered for use with LNG.
- Designed and manufactured in accordance with ASTM B31.1, BSEN 1626 and BS ISO 21011.
- Optional full material traceability backed by BSEN 10204 3.1/3.2 certification.
- 316L Stainless Steel construction for marine applications
- Temperature range -196°C to + 80°C

CV vs Disc Lift at -165°C LNG

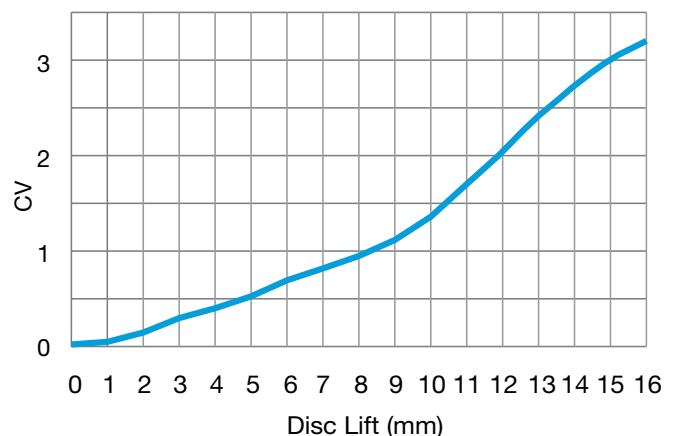



## Materials

	<b>Stainless Steels</b>
1. Body	SS 316L BSEN 10088-3 1.4401/1.4404
2. Cover	SS 316 BSEN 10088-3 1.4401
3. Bonnet Flange	SS 316 BSEN 10088-3 1.4401
4. Disc	Nitronic 60
5. Stem	SS 316 BSEN 10088-3 1.4401
6. Gasket Bonnet	SS 316 / Graphite
7. Gland Packing	PTFE / Graphite / Carbon
8. Fasteners	SS ASTM A320 B8M (Class 2)
9. Actuator	Various
10. Seat	SS 316 BSEN 10088-3 1.4401
11. Seat gasket	Graphite

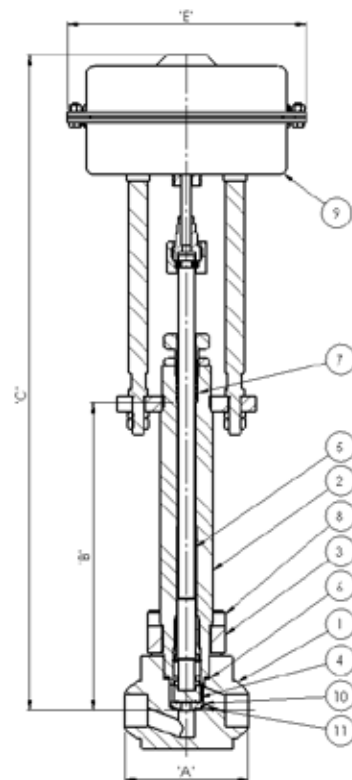

## Specifications

Size	Unit	Dimension
A	mm	145
B	mm	400
C	mm	850
D	mm	-
E	mm	165
Orifice Size	mm	2 or 4
CV	USCGM	3 or 4
End Connections	mm	DN15,20,25, 32, 40, 50, 65
End Connections	Inches	1/2", 3/4", 1", 1 1/4", 1 1/2", 2", 2 1/2"
Pipe Schedule		160/XXS
Weight	kg	40
Extension Length	mm	400
Actuator Type		Single
Model		MA3.16
Closing Force	kN	25

Please contact us for other options.

# Cryogenic HP On/Off Pump De-Gassing Valve

Class 2500 (370 Bar)

DN15 - 25 (1/2" - 1")

**The Parker Bestobell range of HP globe valves have been designed specifically for MAN ME-GI fuel gas systems operating at 320 bar pressure or higher. The HP De-Gassing valve has been specifically designed for use in the pump startup loop of the HP fuel gas system to remove pressure from the pump as it builds up system pressure. It is also required to operate during the pump shutdown.**

The valve is designed to reduce pressure in the main fuel line by safely discharging LNG from 320 Bar to less than 10 Bar through the return pipe to the LNG tank. The CV has been significantly reduced to prevent excessive pressure loss in the main fuel line. The valve is supplied with a removable orifice plate so that the CV can be adjusted during commissioning if needed. By adjusting the CV allows for fine tuning of the flow rate and pressure drop through the orifice plate to suit operating conditions

The HP De-Gassing valve is available with various size butt weld connections to suit the pipe size and utilises Parker Bestobell's unique independent bonnet and flange design that eliminates leakage through the flange gasket. Seat leakage at high pressure is also eliminated through careful lapping of the seat and disc faces. The valves are available with 400mm extended stem for use in the cryogenic phase.



HP On/Off Pump De-Gassing Valves

## Maximum Working Pressure (MWP)

Up to 370 bar (5366 psi) at -196°C to +80°C

## Features

- Unique Parker Bestobell loose flange bolted bonnet design allows for thermal expansion and contraction and eliminates leakage at the bonnet gasket
- Removable orifice plate to adjust flow and pressure drop
- Discharge cage to reduce sound and cavitation
- Lapped metal-to-metal seat ensures tight shut off at all times
- Valve is fire safe by design
- Designed and engineered specifically for cryogenic service
- Anti-blowout spindle and one-piece high strength design for operator safety
- Precision machined one-piece extension tube cover with integral bush for high pressure use
- Fast/easy maintenance of disc
- Long life carbon and graphite gland packing

- Actuators available in "fail open" and "fail close" operation
- Actuators available in marine grade paint for on deck applications

## Technical

- Designed and engineered for use with LNG.
- Designed and manufactured in accordance with ASTM B31.1, BSEN 1626 and BS ISO 21011.
- Optional full material traceability backed by BSEN 10204 3.1/3.2 certification.
- 316L Stainless Steel construction for marine applications
- Temperature range -196°C to + 80°C

## Materials

	<b>Stainless Steels</b>
1. Body	SS 316L BSEN 10088-3 1.4401/1.4404
2. Cover	SS 316 BSEN 10088-3 1.4401
3. Bonnet Flange	SS 316 BSEN 10088-3 1.4401
4. Disc	SS 316 BSEN 10088-3 1.4401
5. Stem	SS 316 BSEN 10088-3 1.4401
6. Gasket Bonnet	SS 316 / Graphite
7. Gland Packing	Graphite / Carbon
8. Fasteners	SS ASTM A320 B8M (Class 2)
9. Actuator	Various
10. Seat	SS 316 BSEN 10088-3 1.4401
11. Hand wheel	SS ASTM A351 CF8M

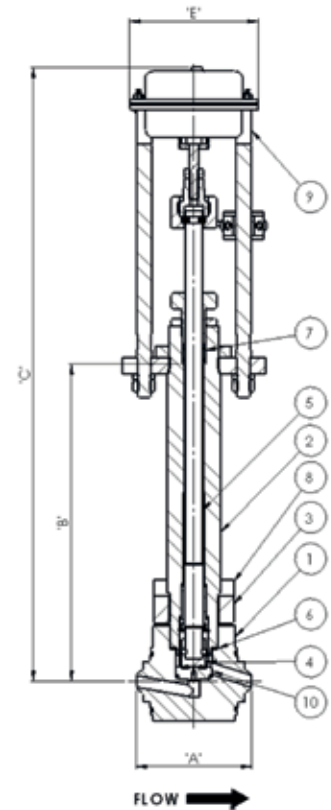

## Specifications

Size	Unit	Actuated	Manual
A	mm	145	145
B	mm	400	400
C	mm	775	610
D	mm	-	600
E	mm	165	230
Orifice Size	mm	0.8/1.2	0.8/1.2
CV		0.02/0.03	0.02/0.03
End Connections	mm	DN15,20,25	DN15,20,25
End Connections	Inches	1/2", 3/4", 1"	1/2", 3/4", 1"
Pipe Schedule		160/XXS	160/XXS
Weight	kg	35	30
Extension Length	mm	400	400
Actuator Type		Single	Hand Wheel
Model		MA3.16	-
Closing Force	kN	20	-

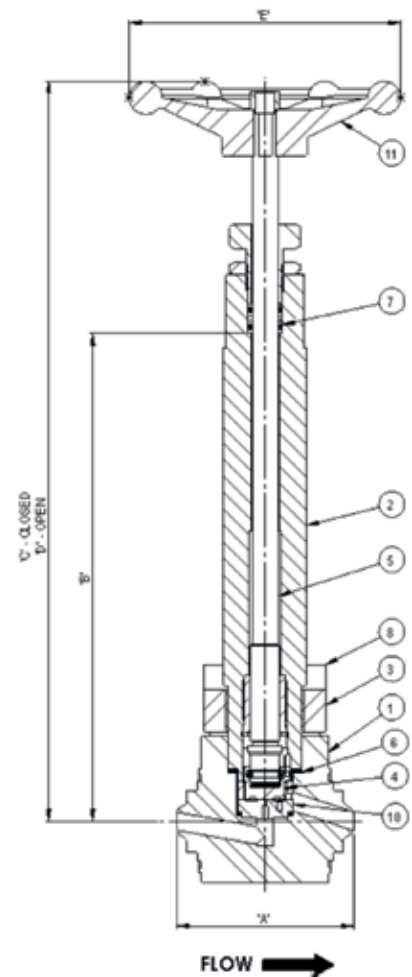

Please contact us for other options.

# Cryogenic HP Lift Check Valve

Class 2500 (370 Bar)

DN15 - 100 (1/2" - 4")

**The Parker Bestobell range of HP globe valves have been designed specifically for the MAN ME-GI fuel gas systems operating at 320 bar pressure or higher. The range covers all of the necessary check valve applications within the system.**

The range is offered with four CV profiles from 5 USGPM up to 30 USGPM, and two standard body sizes. These will cover both cryogenic and gas phases in the system. Pressure drop can be minimised by selecting the correct CV profile for the system conditions and flow rates. The end connection can then be machined to suit.

The range is available with various size butt weld connections and utilises Parker Bestobell's unique independent bonnet and flange design that eliminates leakage through the flange gasket. Seat leakage at high pressure is also eliminated through careful lapping of the seat and disc faces.

The lift check valves are suitable for use in both cryogenic and gas phases.



HP Lift Check Valve

## Maximum Working Pressure (MWP)

- Up to 370 bar (5366 psi) at -196°C to +80°C

## Features

- Unique Bestobell loose flange bolted bonnet design allows for thermal expansion and contraction and eliminates leakage at the bonnet gasket
- Lapped metal-to-metal seat ensures tight shut off at all times
- Valve is fire safe by design
- Designed and engineered specifically for cryogenic service
- One-piece high strength design for safety
- Precision machined one-piece body and extension tube cover with integral bush for high pressure use.
- Fast/easy maintenance of disc
- Vented disc to prevent locking in the open position and ensures fast reaction closing under back pressure.

## Technical

- Designed and engineered for use with LNG.
- Designed and manufactured in accordance with ASTM B31.1, BSEN 1626 and BS ISO 21011.
- Optional full material traceability backed by BSEN 10204 3.1/3.2 certification.
- 316L Stainless Steel construction for marine applications
- Temperature range -196°C to + 80°C

## CV15: Pressure Drop v Flow At -163°C LNG

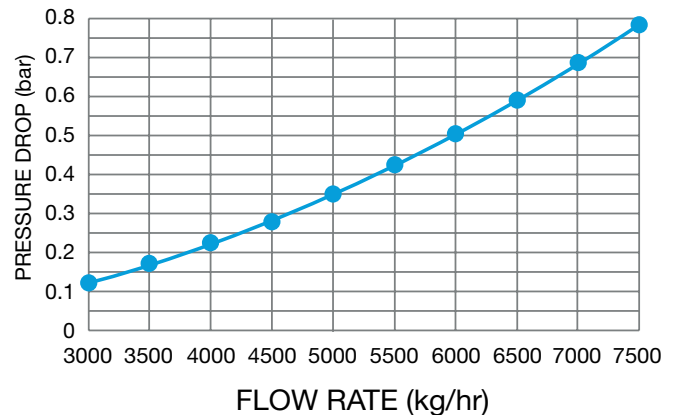

## Materials

1. Body	SS 316L BSEN 10088-3 1.4401/1.4404
2. Cover	SS 316 BSEN 10088-3 1.4401
3. Bonnet Flange	SS 316 BSEN 10088-3 1.4401
4. Disc	SS 316 BSEN 10088-3 1.4401
5. Fasteners	SS ASTM A320 B8M (Class 2)
6. Gasket	SS 316 / Graphite

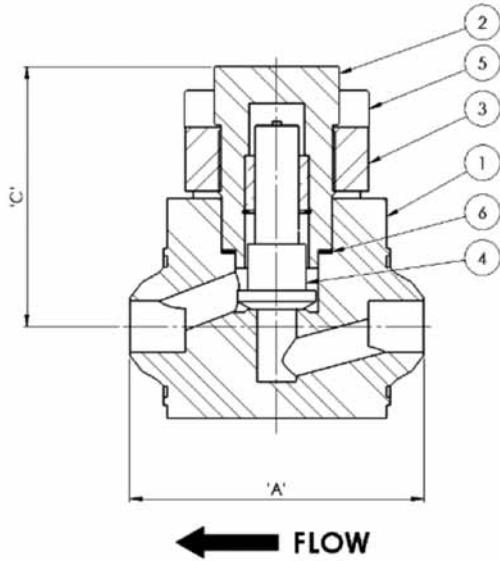

CV 5/10/15

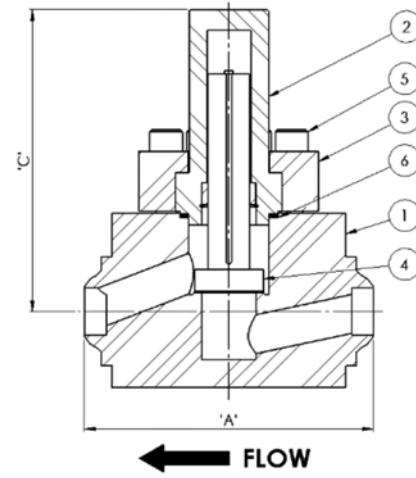

CV 20/25/30

## Specifications

Size	Unit	CV5	CV10	CV15	CV30
A	mm	145	145	160	160
C	mm	160	160	160	280
End Connections	mm	DN15,20,25, 32,40,50, 65			DN50,65,80,100
End Connections	Inches	½", ¾", 1", 1¼", 1½", 2", 2½"			2", 2 ½", 3", 4"
Pipe Schedule		40/80/160/XXS	160/XXS	160/XXS	160/XXS
Weight	kg	14	14	14	50

Please contact us for other options.

# Notes

# Sales Offices Worldwide

## Europe, Middle East, Africa

**AE – United Arab Emirates, Dubai**  
Tel: +971 4 8127100  
parker.me@parker.com

**AT – Austria, Wiener Neustadt**  
Tel: +43 (0)2622 23501-0  
parker.austria@parker.com

**AT – Eastern Europe, Wiener Neustadt**  
Tel: +43 (0)2622 23501 900  
parker.easteurope@parker.com

**AZ – Azerbaijan, Baku**  
Tel: +994 50 2233 458  
parker.azerbaijan@parker.com

**BE/LU – Belgium, Nivelles**  
Tel: +32 (0)67 280 900  
parker.belgium@parker.com

**BG – Bulgaria, Sofia**  
Tel: +359 2 980 1344  
parker.bulgaria@parker.com

**BY – Belarus, Minsk**  
Tel: +48 (0)22 573 24 00  
parker.poland@parker.com

**CH – Switzerland, Etoy**  
Tel: +41 (0)21 821 87 00  
parker.switzerland@parker.com

**CZ – Czech Republic, Klecany**  
Tel: +420 284 083 111  
parker.czechrepublic@parker.com

**DE – Germany, Kaarst**  
Tel: +49 (0)2131 4016 0  
parker.germany@parker.com

**DK – Denmark, Ballerup**  
Tel: +45 43 56 04 00  
parker.denmark@parker.com

**ES – Spain, Madrid**  
Tel: +34 902 330 001  
parker.spain@parker.com

**FI – Finland, Vantaa**  
Tel: +358 (0)20 753 2500  
parker.finland@parker.com

**FR – France, Contamine s/Arve**  
Tel: +33 (0)4 50 25 80 25  
parker.france@parker.com

**GR – Greece, Athens**  
Tel: +30 210 933 6450  
parker.greece@parker.com

**HU – Hungary, Budaörs**  
Tel: +36 23 885 470  
parker.hungary@parker.com

**IE – Ireland, Dublin**  
Tel: +353 (0)1 466 6370  
parker.ireland@parker.com

**IL – Israel**  
Tel: +39 02 45 19 21  
parker.israel@parker.com

**IT – Italy, Corsico (MI)**  
Tel: +39 02 45 19 21  
parker.italy@parker.com

**KZ – Kazakhstan, Almaty**  
Tel: +7 7273 561 000  
parker.easteurope@parker.com

**NL – The Netherlands, Oldenzaal**  
Tel: +31 (0)541 585 000  
parker.nl@parker.com

**NO – Norway, Asker**  
Tel: +47 66 75 34 00  
parker.norway@parker.com

**PL – Poland, Warsaw**  
Tel: +48 (0)22 573 24 00  
parker.poland@parker.com

**PT – Portugal**  
Tel: +351 22 999 7360  
parker.portugal@parker.com

**RO – Romania, Bucharest**  
Tel: +40 21 252 1382  
parker.romania@parker.com

**RU – Russia, Moscow**  
Tel: +7 495 645-2156  
parker.russia@parker.com

**SE – Sweden, Spånga**  
Tel: +46 (0)8 59 79 50 00  
parker.sweden@parker.com

**SK – Slovakia, Banská Bystrica**  
Tel: +421 484 162 252  
parker.slovakia@parker.com

**SL – Slovenia, Novo Mesto**  
Tel: +386 7 337 6650  
parker.slovenia@parker.com

**TR – Turkey, Istanbul**  
Tel: +90 216 4997081  
parker.turkey@parker.com

**UA – Ukraine, Kiev**  
Tel: +48 (0)22 573 24 00  
parker.poland@parker.com

**UK – United Kingdom, Warwick**  
Tel: +44 (0)1926 317 878  
parker.uk@parker.com

**ZA – South Africa, Kempton Park**  
Tel: +27 (0)11 961 0700  
parker.southafrica@parker.com

## North America

**CA – Canada, Milton, Ontario**  
Tel: +1 905 693 3000

**US – USA, Cleveland**  
Tel: +1 216 896 3000

## Asia Pacific

**AU – Australia, Castle Hill**  
Tel: +61 (0)2-9634 7777

**CN – China, Shanghai**  
Tel: +86 21 2899 5000

**HK – Hong Kong**  
Tel: +852 2428 8008

**IN – India, Mumbai**  
Tel: +91 22 6513 7081-85

**JP – Japan, Tokyo**  
Tel: +81 (0)3 6408 3901

**KR – South Korea, Seoul**  
Tel: +82 2 559 0400

**MY – Malaysia, Shah Alam**  
Tel: +60 3 7849 0800

**NZ – New Zealand, Mt Wellington**  
Tel: +64 9 574 1744

**SG – Singapore**  
Tel: +65 6887 6300

**TH – Thailand, Bangkok**  
Tel: +662 186 7000

**TW – Taiwan, Taipei**  
Tel: +886 2 2298 8987

## South America

**AR – Argentina, Buenos Aires**  
Tel: +54 3327 44 4129

**BR – Brazil, Sao Jose dos Campos**  
Tel: +55 800 727 5374

**CL – Chile, Santiago**  
Tel: +56 2 623 1216

**MX – Mexico, Toluca**  
Tel: +52 72 2275 4200



Parker Hannifin Manufacturing Ltd  
**Instrumentation Products Division Europe**  
President Park, President Way  
Sheffield S4 7UR  
United Kingdom

Tel: +44 114 224 0000  
www.parker.com/ipd

**EMEA Product Information Centre**  
**Free phone: 00 800 27 27 5374**  
(from AT, BE, CH, CZ, DE, DK, EE, ES, FI, FR, IE, IL, IS, IT, LU, MT, NL, NO, PL, PT, RU, SE, SK, UK, ZA)

**US Product Information Centre**  
**Toll-free number: 1-800-27 27 537**  
www.parker.com